

ETSC
Progress in the traffic enforcement procedure

2022
SPAIN



Jorge Ordás

Deputy Director General for Mobility
Management and Technology.

Traffic General Directorate (DGT)



MINISTERIO
DEL INTERIOR



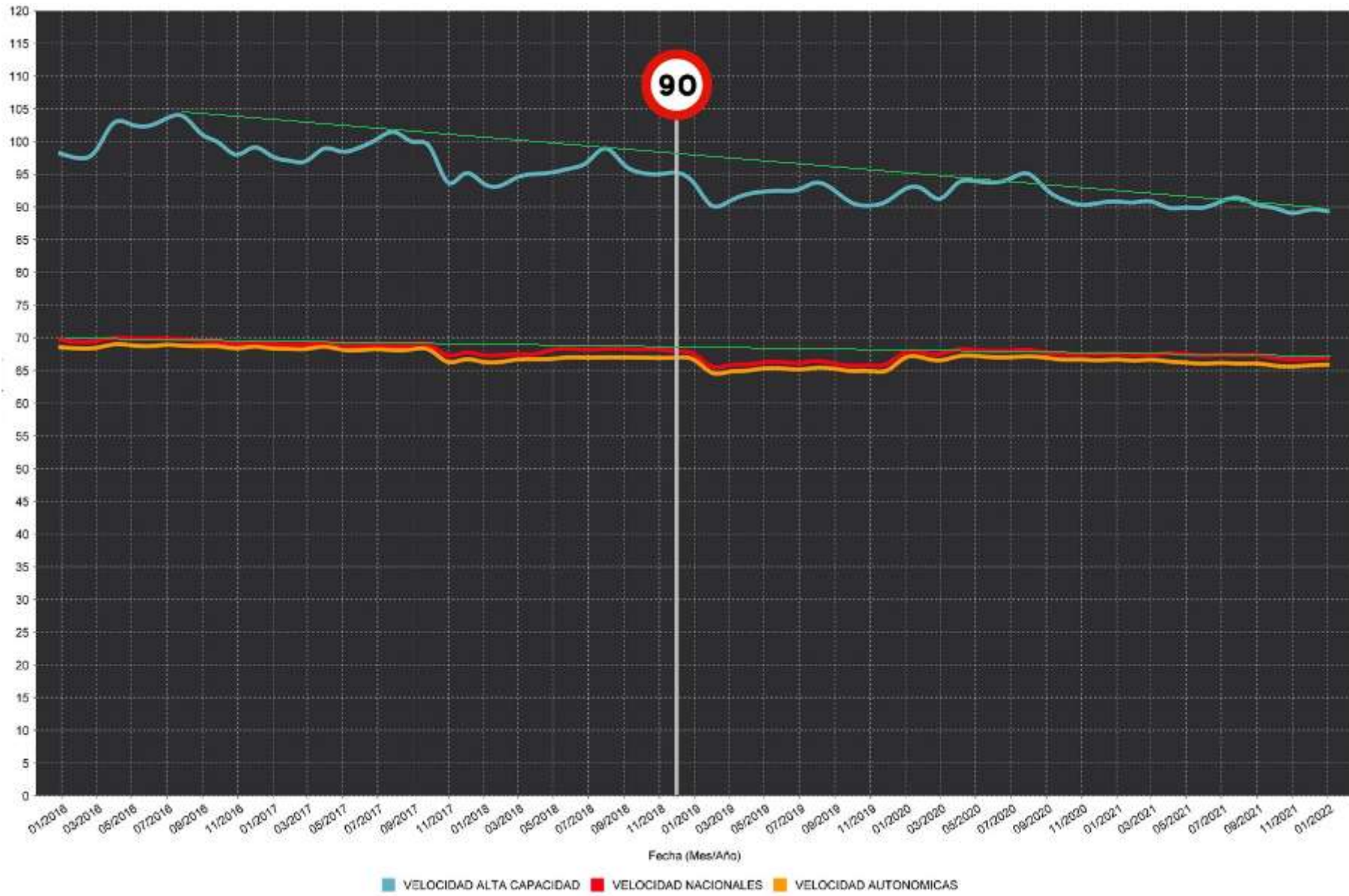

Speed checkpoints

TYPE OF RADAR	AMOUNT
FIXED RADARS	681
SECTION RADARS	92
MOBILE RADARS	536
HELICOPTERS	13
Total	1.322

New criteria:

- 60 % on secondary roads
- 60% section radars

Speed and



SEATBELT

MOBILE PHONE

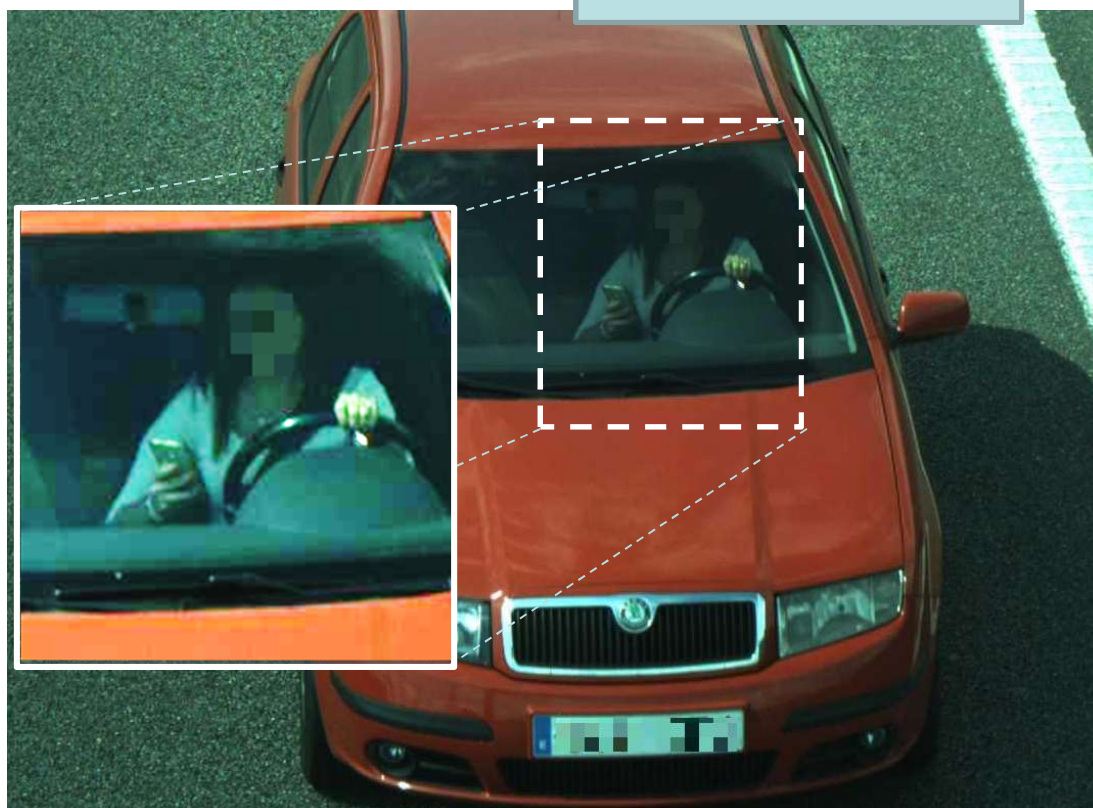

CTDA : Traffic Offence Processing Centre

OTHER CONTROLS. Restrictions, MOT, Trailers.

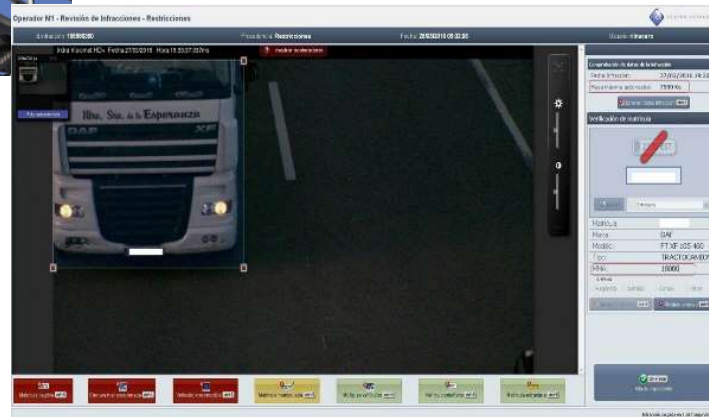

Trailer

Plate:	<input type="text"/>		
Make:	<input type="text"/>		
Model:	<input type="text"/>		
Type:	<input type="text"/>		
0.303 mils			
<input type="checkbox"/> Van	<input type="checkbox"/> Bus	<input type="checkbox"/> Truck	<input type="checkbox"/> Others
<input checked="" type="checkbox"/> Trailer			

TOLL ROAD EVADERS



TYPES OF AUTOMATED FINES

Coming this year

RED LIGHT



VIDEO STOP

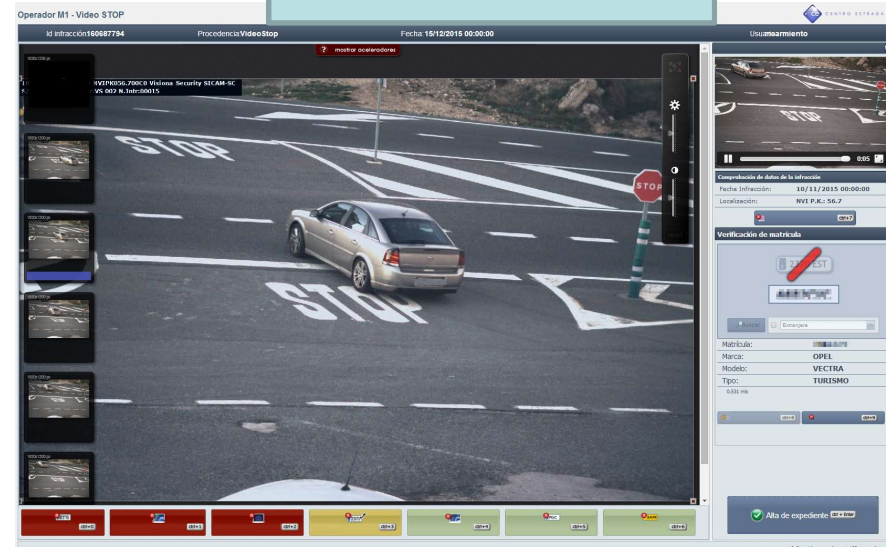

Operador M1 - Video STOP

M infracción160687784

ProcedenciaVideoStop

Fecha: 16/12/2015 00:00:00

Comprobación de datos de la infracción

Fecha infracción: 16/12/2015 00:00:00

Localización: R02.P.C. 54.7

Verificación de matrícula

Alta de expediente

Infracción creada en 1.188 segundos

SPEED CONTROL (Helicopter)

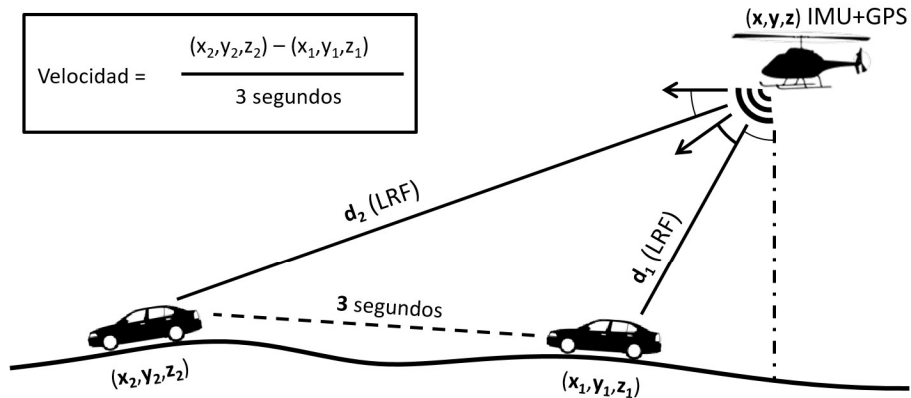

IMU: Inertial Measurement Unit
LRF: Laser Rangefinder





Continuous optical zoom x30
Digital zoom x6.

ZOOM x180



1. Hot Zones (HZ)

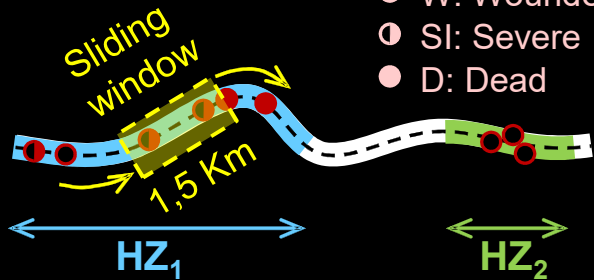

- W: Wounded
- SI: Severe Injury
- D: Dead

2. Representative section

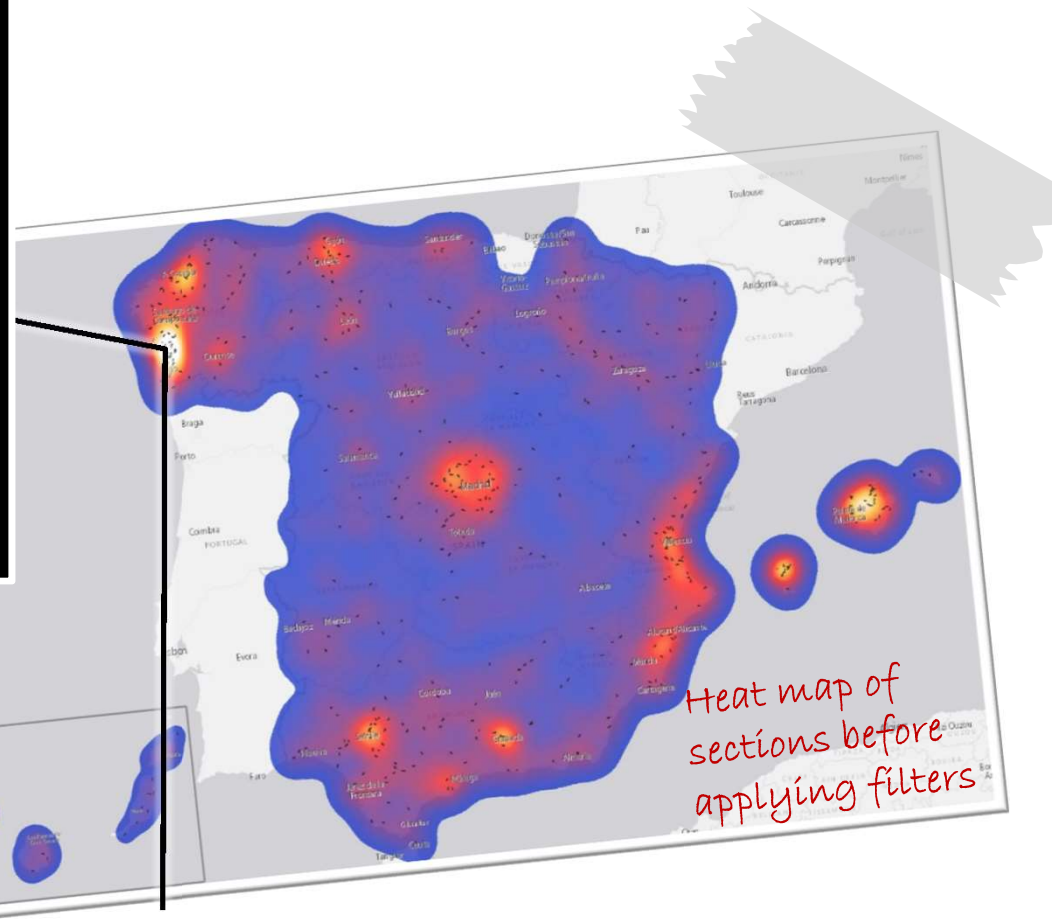
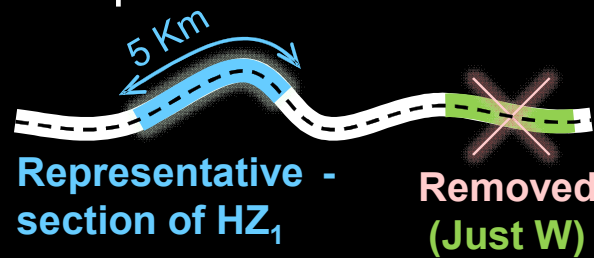

Hot zone (HZ):
A number of collisions with some spatial continuity.

Representative section:
Section of about 5 Km with more D and SI in a HZ.

SPEED: Credibility

- Reasonable speed limits.
- Sensation of control, not for revenue purpose:
 - 2/3 actually equipped cabins
- We inform in advance:
 - Warning signals (0,5 to 2 km before, with speed limit reminder)
 - Locations are published on official website
 - DATEX

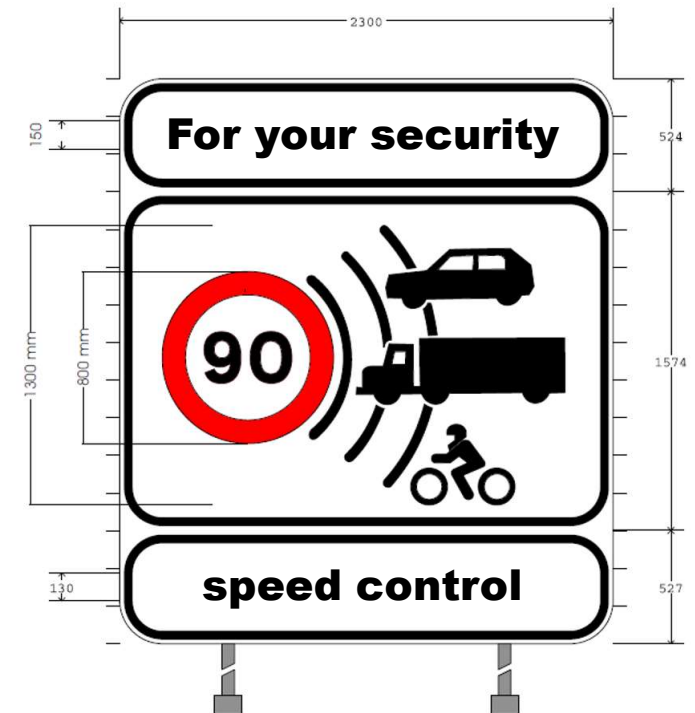

UNIVERSAL CABIN (for secondary roads)

NEW!!!

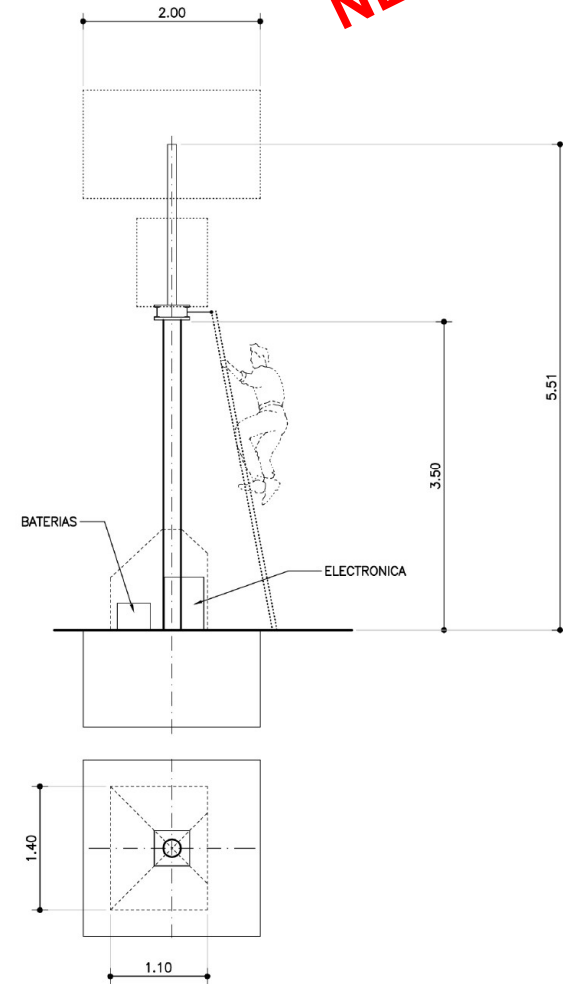
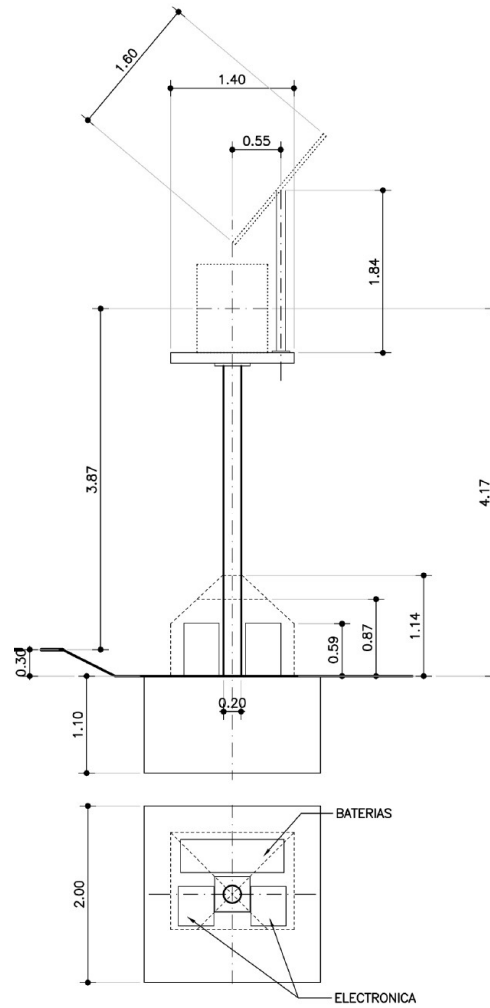

Universal cabin + 2/3 + Rotation

ONLINE Metrologic verification

- No traffic interruption nor risks.
- Time efficient.
- Saving in staff.

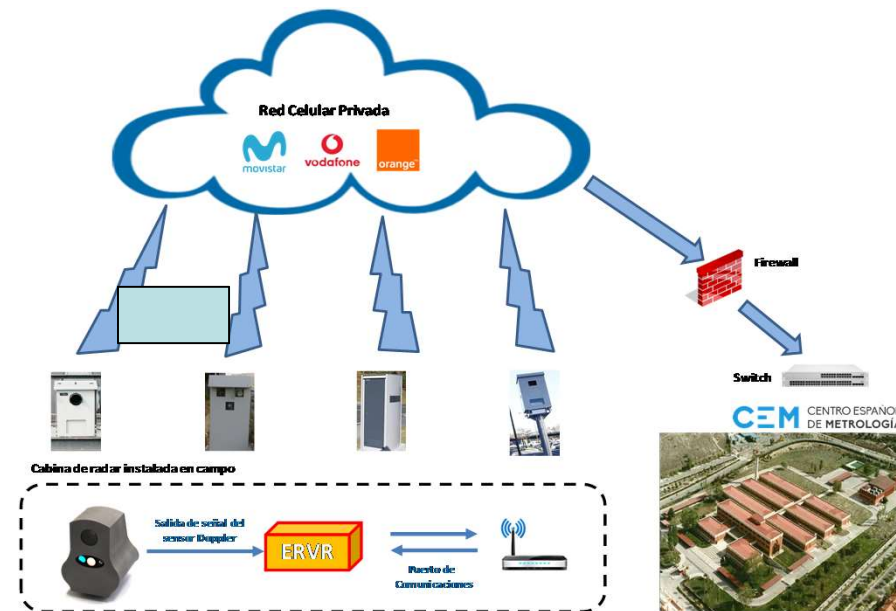

 **Mapa de Radares**

PROVINCIAS
RADARS

Radars information
✕

Provincia Malaga	Carretera A-7
Pk 256.764	Sentido D
Tipo vía Autovía	Límite velocidad 80km/h (Específica)
Multicarril 0	Carril 0
Modelo zenerométrico 6F-MR	Número zona 2499
Instalación	
Gráficos de evolución temporal	





February
2022

Total
166.400

On progress files

1/2014
3/2022

Efficient plate recognition

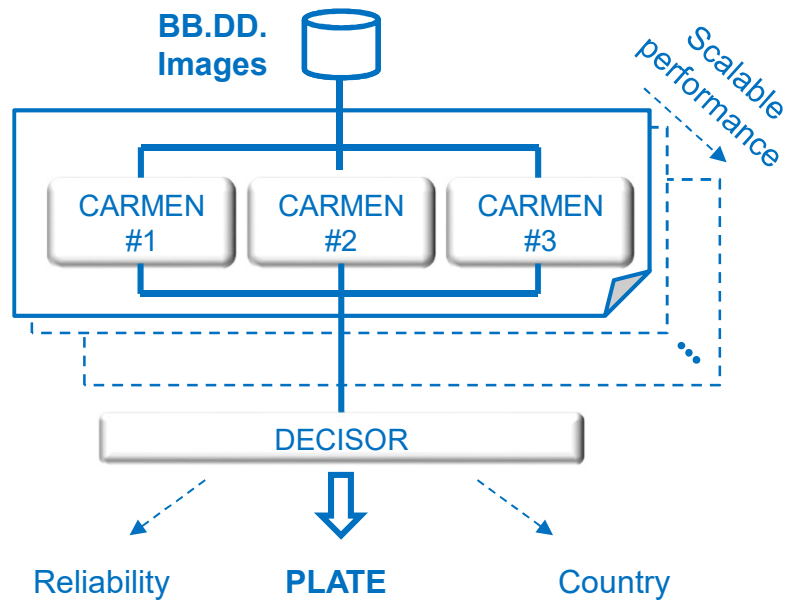

LPR has substantially improved in performance and reliability

		% Volume	% OK
LPR	Reliable	80%	99,6%
	Non-reliable	7%	88,3%
	Not found	13%	53,4%
	Human agent		91,0%

Traffic offences and fines on foreign vehicles

Amount of fines on foreign vehicles in 2021

Country	Traffic Offences
France	58.625
Portugal	44.078
Germany	15.737
Romania	9.850
Poland	8.627
Belgium	8.544
Italy	6.800
Netherlands	6.409
Austria	307
Total	158.977

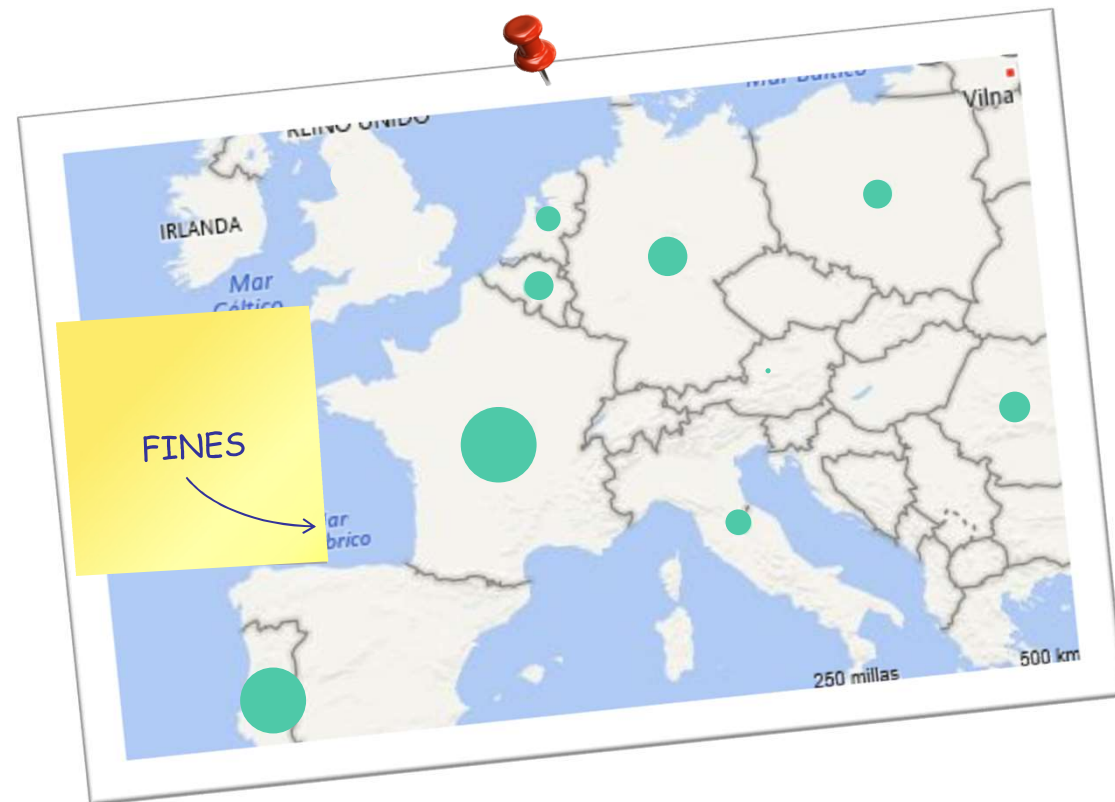



CTDA (Traffic Offence Processing Centre)

- Contract based on Service Level Agreement (SLA).
- Traceability the whole process and specially the rejected images:

1. Verification of metrological certificate.
2. Technical double-check of radars.
3. Vehicle Register look up for checking.
4. Unified legal criteria.

Quality controls



Results in 2021

- ✓ 82% of radars operational.
- ✓ 2.797.587 fines.
- ✓ Citizens receive notifications within 7 days after the traffic offence.
- ✓ Just 1,74 % result in a written claim against the fine.
- ✓ Just 5 out of 10.000 end up in a Court of Justice.

**THANKS FOR
YOUR ATTENTION**



MINISTERIO
DEL INTERIOR

